

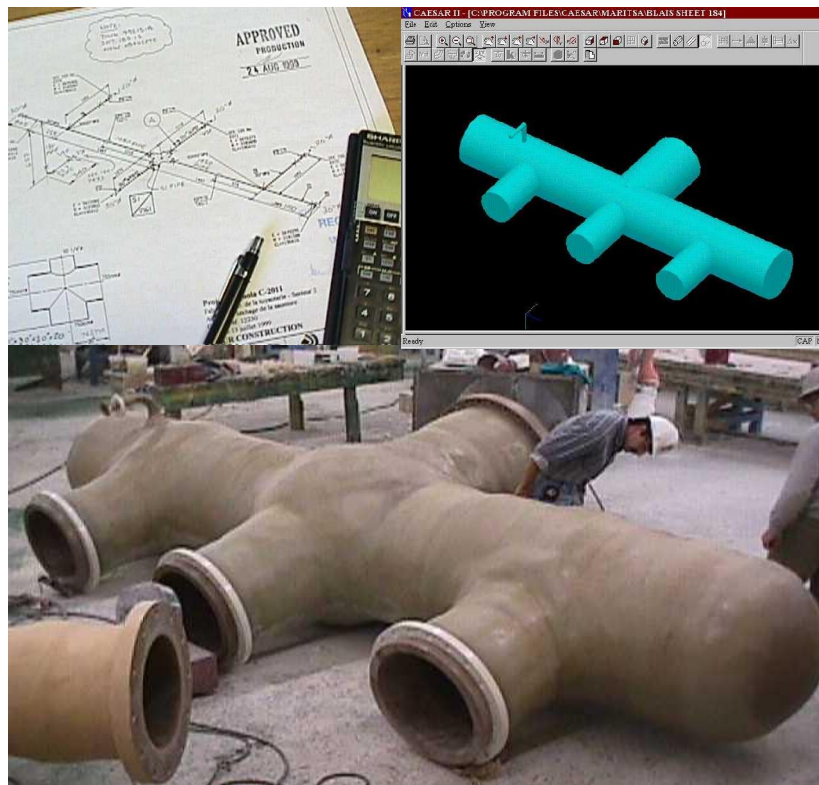

DESIGN MANUAL



REINFORCED PLASTIC SYSTEMS INC.

740 South Main Street
P.O. Box 299
Mahone Bay, Nova Scotia, Canada
B0J 2E0

Tel: (902) 624-8383 / (800) 343-9355
Fax: (902) 624-6395
E-mail: rps@rps.ca
Website: www.rps.ca



TABLE OF CONTENTS

Section	Page
INTRODUCTION	3
DESCRIPTION OF FRP MATERIALS	3
Glass Reinforcements	3
Resins	4
Additives	4
MANUFACTURING	5
Filament Winding	5
Custom Contact Molding	5
PIPE PROPERTIES	7
General Physical Properties	7
Mechanical Properties of Filament Wound Pipe	7
Mechanical Properties of Hand Lay-up Pipe and Fittings	8
Mechanical Properties of Corrosion Barrier	8
Composite Properties	8
HYDRAULICS	9
Friction Loss Calculations	9
Head Loss in Fittings	9
Transient Pressures	10
ABOVE GROUND PIPE & FITTING DESIGN	11
Filament Wound Pipe Design	11
Contact Molded Pipe & Fitting Design	12
Pressure Stress Multipliers and Fitting Design	12
Design for Vacuum	12
ABOVE GROUND PIPING SYSTEM DESIGN	13
Differences between FRP and Steel & General Recommendations	13
Recommended Hanger Spacing for 150 psi Rated Piping	14
Pipe Supports	15
Design for Thermal Expansion	15
Pipe Stress Analysis and Allowable Stress	19
BURIED PIPE DESIGN & INSTALLATION	21
JOINING SYSTEMS	24
QUALITY ASSURANCE and RESEARCH & DEVELOPMENT	26
REFERENCES	26



INTRODUCTION

REINFORCED PLASTIC SYSTEMS INC. (RPS) produces fibreglass reinforced plastic (FRP) pipe and fittings intended for use in a wide variety of applications. The intent of this manual is to provide designers and users with the tools necessary to confidently design or specify above-ground or buried piping systems utilizing RPS components.

DESCRIPTION OF FRP MATERIALS

Fibreglass reinforced plastics are composite products consisting of glass reinforcement embedded in thermosetting resin. The usage of FRP has grown steadily over the past three decades due to the advantages that FRP offers over traditional materials. Some of the advantages of FRP are:

- Excellent Corrosion Resistance
- High strength to weight ratio
- Light weight compared to most metals
- Non-conductive to electricity
- Dimensionally stable
- Low maintenance costs
- Unlimited shape/size configurations
- Orthotropic in nature (different properties in different directions)

FRP consists of three main components:

- Glass Reinforcements
- Resin
- Additives

A description of these components, and how they are used at RPS is summarized below:

Glass Reinforcements



The mechanical strength of FRP depends on the type, amount, and orientation of the glass reinforcement within the part. The strength of an FRP laminate will increase as

more layers of glass reinforcement are used and as the ratio of glass to resin is increased.(i.e more glass per unit volume). Several types of glass reinforcements are utilized at RPS and can be summarized as follows:

- **CHOPPED STRAND MAT** – This type of reinforcement utilizes short glass fibres (typically ½" to 2" long), randomly oriented and held together with a resinous binder. Chopped strand mat provides good chemical resistance due to the high resin, low glass ratio achieved in the application of the material. Since the glass fibres are not continuous, it is difficult for chemicals to penetrate the laminate by following along the fibre. Thus, the chopped strand mat in the corrosion barrier is often referred to as the “anti-wicking” barrier. Chopped strand mat is available in a variety of weights with 1-1/2 oz. per square foot the most commonly utilized.
- **WOVEN ROVING** – Also commonly used, this type of reinforcement utilizes glass fibres orientated in the 0°/90° directions. Unlike chopped stand mat, the fibres are continuous and no binder is used to hold the arrangement together. Woven roving lacks the chemical resistance of chopped strand mat due to the continuity of the glass fibres and high glass content; however; it does offer increased strength. Typically, laminates over ¼" thick should incorporate woven roving, where possible, to improve strength properties. Woven roving layers should always be preceded and followed by chopped strand mat layers to maximize adhesion. Woven Roving is commonly used with a glass weight of 24 oz. per square yard (2.67 oz. per square foot).
- **CONTINUOUS ROVING** – This type of reinforcement is used in the structural layers of filament wound piping and in the structural layers of some fittings, such as on the exterior of larger diameter elbows. The high glass content (low resin content) created by applying the continuous rovings provides high strength in the direction of the fibre. Continuous rovings should not be exposed to chemical environments as they could allow “wicking” of chemicals into the laminate.
- **SURFACING VEIL** – As the name implies, surfacing veils are generally only used on the surface of laminates. The veil layer provides a high resin to reinforcement ratio (typically 90:10), which creates excellent chemical resistance at the parts surface, where it is most needed. All corrosion barriers in RPS products are started with one layer of surfacing veil. For increased chemical resistance, two layers of veil can be used; however, beyond this, the corrosion barrier may be susceptible to cracking due to the high resin content created with the surfacing veil. Nexus surfacing veil is a polyester product, which provides good chemical resistance, appearance and workability. “C” glass veil is a corrosion resistant glass



veil which also provides good characteristics. The choice to use C glass veil versus Nexus is usually a matter of preference concerning workability, with most manufacturers using one or the other. It should be noted, however, that C glass veil is not generally recommended in services containing fluorides.

- **OTHER REINFORCEMENTS** – A wide variety of reinforcements exist which can be used to meet specific needs (e.g. Carbon veil for electrical conductivity). RPS is experienced in the design of products utilizing various reinforcements and can provide assistance in choosing the right reinforcements for the job.

Resins

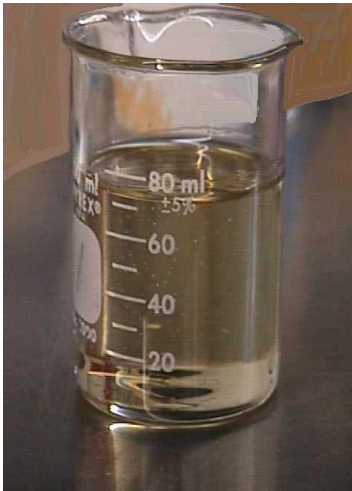

The second major component of FRP piping is the resin system. FRP is fabricated using thermosetting resins. These types of resins are cured using chemical additives; and once cured, are essentially infusible (unlike thermoplastic resins, which can be re-melted). In an FRP laminate, the resin acts to hold the reinforcement in place

and the resin system is chosen for its chemical, mechanical and thermal properties as well as its processing ability.

RPS uses a wide variety of resins as summarized below:

- **BIS-A VINYL ESTER** – The most commonly used resin at RPS, vinyl esters provide excellent chemical resistance, excellent resilience and good workability.
- **EPOXY NOVOLAC VINYL ESTER** – Used in RPS “H” series piping, Epoxy Novolacs offer increased chemical resistance to strong acids and higher temperature capability compared to BIS-A type vinyl esters.
- **ISOPHTHALIC POLYESTER** – Used in RPS “I” series piping, Isophthalic’s or “Iso’s” offer good chemical resistance at lower cost compared to vinyl esters. In mild to moderate corrosive applications, isophthalic’s can be an economical alternative.

- **FIRE RETARDENT RESINS** – All of the resin types mentioned above are available in fire retardant versions. These fire retardant derivatives generally incorporate bromine and antimony compounds to improve fire resistance and create a laminate, which is self-extinguishing when the flame source is removed. Most fire retardant resins will provide a Class 1 flame spread rating when tested in accordance to ASTM E-84.
- **OTHER RESINS** – RPS also has experience in the use of many other resins including:
 - Chlorendic Polyesters
 - Bisphenol Fumarates
 - Phenolics
 - Terephthalic
 - And others

Additives

A number of additives are used in FRP laminates. Some of the most common additives are briefly described below:

- **Catalyst/Promoters** – Thermosetting resins require both catalysts and promoters to cure. Again, a wide variety of options exist such as MEKP (methyl ethyl ketone peroxide), BPO (benzoyl peroxide), CHP (cumene hydrogen peroxide), DMA (dimethyl aniline), CoNap (cobalt naphenate) and others. Resin suppliers provide recommendations regarding correct levels of catalysts and promoters, and these should be strictly adhered to. The choice of which catalyst/promoter system to use is usually a matter of fabricator preference, however, in some applications, superior performance can be achieved with one over the other (eg. BPO/DMA for Sodium Hypochlorite service).
- **Thixotropes** – These are generally silica based products which add thixotropy to minimize drain-out of resin.
- **Gel Time Retarders** – Chemicals such as 2,4-Pentanedione slow the cure process. They are generally used in large parts fabrication.
- **Pigments** – Pigments can be added to laminates and exterior coatings to impart unlimited colour options and to provide resistance to UV degradation.
- **Antimony Compounds** – These compounds increase fire resistance when used with a fire retardent resin.



- Paraffin – Used in top coats of laminates to seal the surface and allow for proper cure at the surface.
- Abrasion Resistant Fillers – RPS “A” and “AA” series pipe and fittings include abrasion resistant fillers added to the corrosion barrier for use in services where abrasion is a concern.
- Others – Other additives such as antifoaming agents, carbon black, and milled fibres, are used to impart specific properties.

MANUFACTURING



RPS manufactures FRP piping systems, duct, tanks and stacks from 1" (25mm) to 18' (5.5m) diameter. A variety of techniques

using varying degrees of automation are used to fabricate the various components. Each technique produces a product with unique characteristics. These techniques are summarized below:

Filament Winding



The majority of pipe and ducting produced at RPS is manufactured by the filament winding process. Filament winding involves pulling glass fibres, under controlled

tension, through a catalyzed resin bath. The resin bath travels back and forth passed a rotating mandrel, with the angle of fibre placement determined by the translational speed of the resin bath relative to the rotational speed of the mandrel. Through this motion, a pattern is established and repeated until the desired thickness is achieved. RPS utilizes both mechanical and computerized electromechanical filament winding machines to produce high quality, consistent parts. The tension of the glass fibres produces a laminate with high glass content, typically 70% by weight, creating a strong structural cage, highly orthotropic in nature. Prior to filament winding, a

corrosion barrier, generally consisting of surfacing veil and chopped strand glass reinforcement, is applied to the mandrel by contact molding.

Custom Contact Molding



In contrast to piping, the majority of fittings at RPS are manufactured using the custom contact molding technique. Using this approach, resin and glass are

applied by spray gun, or by hand to stationary or rotating molds. The resin/reinforcement combination is “rolled out” to remove entrapped air, compact the layers, and ensure complete wet-out of the glass fibres. The number of layers that can be continuously applied to the mold is limited since heat generated by the resin cure may create blistering in the part. To prevent this, laminates are laid-up in stages, which are allowed to cure and cool before the next stage of reinforcement is applied. Each sequence of reinforcement must begin and end with a layer of chopped strand glass to provide proper adhesion.



The contact molding technique provides for an unlimited number of plies and orientation of reinforcement, allowing the designer to

place the material where it is most needed. This creates parts which range from quasi-isotropic to highly orthotropic. The manual nature of the technique means a high skill level is required to produce a high quality, consistent part. Materials such as chopped stand glass, woven roving, Nexus veil, C-veil, and unidirectional reinforcement are all applied using this technique. Traditionally, most corrosion barriers are applied by contact molding.

As mentioned above, the contact molding technique is generally broken down into two sub-methods; namely, hand lay-up and spray-up. As the name implies, hand lay-up involves saturating glass reinforcement and applying this material by hand to the mold.



Alternatively, a chopper gun can be used to mechanically apply the glass reinforcement. With this technique, one or more strands of glass fibre are fed into a gun which cuts or “chops” the glass to a set length (typically 1" to 1¼" long). The chopped glass is then propelled into a stream of catalyzed

resin. Glass content is controlled by adjusting the flow of resin relative to the speed of the chop. The amount of time the chopper gun is held in one spot determines how thick or how much material is applied. The chopper gun can be used alone to produce an “all chop” component, which would be similar to a laminate made of “all chopped strand mat”. Alternatively, the chopper gun can be used in conjunction with hand lay-up material, such as woven roving, to produce a laminate with higher glass content and strength. The resin spraying ability of the chopper gun can also be used alone to “wet-out” hand lay-up laminates, which can reduce labour costs on larger parts.



PIPE AND FITTING PROPERTIES

FRP is a composite material and can have different properties in different directions. Some general physical properties are essentially the same for all FRP products produced at RPS. However, most mechanical properties are significantly different in the Axial (Longitudinal) versus Hoop (Circumferential) directions. It should be

noted that the corrosion/abrasion layer included in all RPS products is generally not considered in structural design of pipe; however, it is often necessary to know the properties of the corrosion liner and the composite properties of the laminate (refer to the section Pipe Stress Analysis for more information on this subject).

GENERAL PHYSICAL PROPERTIES of RPS FRP PIPE & FITTINGS *		
Coefficient of Thermal Expansion	1.2 to 1.5 x 10 ⁻⁵ in./in./deg. F.	2.2 to 2.7 x 10 ⁻⁵ mm/mm/deg. C.
Thermal Conductivity	1.3 BTU in./ft. ² /deg. F/hr.	188 (W-mm)/(m ² deg. C)
Density	0.058 lb/in. ³	1.61 g/cm. ³
Hazen William's Flow Coefficient	150	
Manning's Flow Coefficient	0.009	

* These are approximate values, if exact values are required consult RPS Engineering

MECHANICAL PROPERTIES of A-150 & P-150 FILAMENT WOUND STRUCTURAL LAYERS		
Ultimate Tensile & Compressive Strength		
Hoop	40,000 psi	(276 Mpa)
Axial (due to pressure)	20,000 psi	(138 Mpa)
Axial (due to bending)	12,000 psi	(83 Mpa)
Tensile & Compressive Modulus of Elasticity		
Hoop	2.3 x 10 ⁶ psi	(15,860 Mpa)
Axial	1.4 x 10 ⁶ psi	(9,655 Mpa)
Poisson's Ratio		
Change in axial strain caused by hoop stress		0.7
Change in hoop strain caused by axial stress		0.4



MECHANICAL PROPERTIES of A-150 & P-150 HAND LAY-UP STRUCTURAL LAYERS		
Ultimate Tensile & Compressive Strength		
Hoop/Axial (laminates < 1/4" thick*)	14,000 psi	(96 Mpa)
Hoop/Axial (laminates ≥ 1/4" thick**)	20,000 psi	(138 Mpa)
Tensile & Compressive Modulus of Elasticity		
Hoop/Axial (laminates < 1/4" thick*)	1.2 x 10 ⁶ psi	(8,276 Mpa)
Hoop/Axial (laminates ≥ 1/4" thick**)	1.7 x 10 ⁶ psi	(11,724 Mpa)
Poisson's Ratio, hoop/axial & axial/hoop 0.34*, 0.25**		
* Indicates "all mat" construction ** Indicates mat and woven roving construction		

MECHANICAL PROPERTIES A-150 & P-150 CORROSION BARRIER		
Ultimate Tensile & Compressive Strength		
Hoop/Axial	10,000 psi	(69 Mpa)
Tensile & Compressive Modulus of Elasticity		
Hoop/Axial	1.0 x 10 ⁶ psi	(6,897 Mpa)
Poisson's Ratio, hoop/axial & axial/hoop 0.34		

Composite Properties

The composite properties of an FRP laminate can be estimated by simply proportioning structure and liner properties with thickness. This is demonstrated below.

Example: 12" diameter Filament Wound Pipe

t liner = 0.11"
t winding = 0.26"
total thickness = 0.37"

$$\begin{aligned}
 \text{Composite Tensile Modulus (hoop)} &= \text{Modulus of Liner} \times \frac{\text{Liner thickness}}{\text{Total thickness}} + \text{Modulus of Structure} \times \frac{\text{Structure thickness}}{\text{Total Thickness}} \\
 &= 1.0\text{e}6 \times \frac{0.11}{0.37} + 2.3\text{e}6 \times \frac{0.26}{0.37} = 1.91\text{e}6 \text{ psi}
 \end{aligned}$$

This technique can also be used to estimate other composite properties such as Poisson's ratio.



HYDRAULICS



RPS fibreglass piping offers significant advantages over steel piping in terms of flow characteristics. The smooth interior of FRP piping minimizes friction loss.

Furthermore, it is not necessary to degrade friction factors as the surface remains smooth over time for most applications. The inside diameter of RPS FRP is also larger than most schedule steel piping providing increased capacity.

Friction Loss Calculations

Friction loss, or head loss, is generally calculated using one of three methods. Namely, Hazens-Williams, Manning’s, or Darcy-Weisbach. Each of the methods has its relative merits, disadvantages, and limitations; and the designer should be aware of which formula to use for the given application. The equations and parameters, which relate to RPS FRP piping, are summarized below:

Hazen-Williams Equation – This equation is valid for turbulent flows for piping under full flow, and generally provides a conservative solution for head loss in FRP pipe.

$$hf = 0.2083 (100 \cdot Q / C)^{1.85} / d^{4.87}$$

where,

- hf = Friction loss, ft H₂O/100 ft of piping
- C = Hazen William’s coefficient = 150 for RPS pipe
- Q = Flow rate, gpm (U.S.)
- d = Inside diameter, inches

Manning’s Equation – This equation is generally used to determine the head loss in sewers and drains since it is valid for partial flow under the influence of elevation head only.

$$Q_m = (1.486 / n) (S)^{0.5} \cdot A \cdot R^{0.667}$$

where,

- Q_m = Flow rate, cfs
- n = Manning’s coefficient = 0.009 for RPS pipe
- S = Hydraulic gradient of slope
- A = Cross sectional area of pipe, ft²
- R = Hydraulic radius = Area / wetted perimeter, ft.

Darcy-Weisbach Equation – This equation applies to all fluids and full pipe flows. The primary advantage of the equation is that it is valid for laminar and turbulent flow. However, the friction factor used in the equation is variable.

$$H_F = f \cdot L (V^2) / (2 \cdot ID \cdot g)$$

where,

- H_F = Head loss, ft
- f = Friction factor (see below)
- L = Total length of pipe, ft
- V = Fluid velocity, fps
- ID = Inside diameter, ft
- g = Gravitational constant = 32.2 ft/sec²

The friction factor depends on the flow regime.

For laminar flow, f = 64/Re

Where,

Re = Reynold’s number = ID · V / μ

and,

μ = Fluid kinematic viscosity, ft²/sec

For turbulent flow (i.e Re>3000) the friction factor can be determined using the Moody diagram. RPS FRP piping has a surface roughness parameter (e) equal to 1.7 x 10⁻⁵ ft. The roughness parameter divided by the diameter (ft.) is known as the relative roughness. By using the relative roughness and Reynold’s number, the designer can look-up the appropriate friction factor using the smooth pipe segment of the Moody Diagram.

Head Loss in Fittings

The above equations can be used to calculate the head loss for a given length of piping. However, when fittings are introduced into the system, the head loss can be significantly increased. A common method for dealing with head loss in fittings is to calculate an “equivalent pipe length” which is added to the straight run of pipe. An alternative and more accurate method for determining head loss in fittings is to determine the appropriate loss coefficients or “K” factors. The K factors depend only on the fitting type and do not involve diameter. All the factors are simply summed together and incorporated into the loss equation. This is demonstrated below using the Darcy Weisbach formula.

$$H_f = \{ \text{sum } K's + f_l (L/ID) \} (V^2/2g)$$



Typical “K” factors for FRP fittings are summarized below:

Type of Fitting	K Factor
90° smooth radius elbow	0.5
90° single-mitered elbow	1.4
90° double-mitered elbow	0.8
90° triple-mitered elbow	0.6
Tee, straight flow	0.4
Tee, flow to branch	1.4
Tee, flow from branch	1.7
Reducer, single size reduction	0.7
Reducer, double size reduction	3.3

Transient Pressures

Transient pressures such as “Water Hammer” can occur when fluid velocity inside piping is rapidly changed. The change in velocity can be caused by pump start-ups or valve closings. Under certain conditions, the magnitude of the transient can be sufficient to seriously damage or rupture the piping. The magnitude of water hammer is related to the fluid type, pipe thickness, pipe diameter, pipe elastic modulus, and the change in fluid velocity. The pressure surge, which is in addition to the operating pressure in the system, can be calculated as follows:

$$P_s = (a/g) \cdot (SG/2.3) \cdot (\Delta V)$$

Where,

- a = Wave velocity = $12 / [(\rho/g)(1/k + d \cdot (t/E)]$
- ρ = Fluid density (lb/ft³)
- g = Gravitational constant (32.2 ft/s²)
- k = Bulk modulus of fluid (300,000 psi for water)
- d = Pipe ID (in.)
- t = Pipe wall thickness (in.)
- E = Modulus of elasticity of pipe (psi)
- SG = Specific gravity (dimensionless)
- ΔV = Change in velocity of fluid (ft./sec.)

The inherent flexibility of FRP piping minimizes the magnitude of water hammer; however, care must be taken when starting-up systems and opening and closing valves. In general, steps should be taken to minimize or eliminate water hammer in FRP piping systems.

Gas Flows

Fibreglass piping is generally recommended for above ground gas lines only when the operating pressure is very low. The table below lists the recommended maximum allowable pressure for gas flows versus diameter. For pressures above those listed in the table, external protection is recommended per ASME/ANSI B31.8 “Gas Transmissions and Distribution Piping Systems.”

GAS LINE PRESSURE	
Diameter	Maximum Recommended Pressure
(in.)	(psi)
< 6"	25
8"	14
10"	9
12"	6
14"	5
16"	4

References

For more information on hydraulics refer to:

Pipe Fabricators Institute / SPI - “Fiberglass Pipe Handbook”

American Water Works Association - “Fiberglass Pipe Design – AWWA M45”



ABOVE GROUND PIPE & FITTING DESIGN

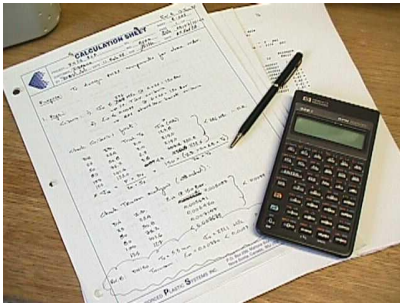

As mentioned earlier, FRP piping utilizes glass fibres to reinforce a resin matrix. The fibres can be orientated in any direction to provide optimum properties. This

feature high-lights the advantage and complexity of FRP design. The methods used to design pipe and fittings are briefly summarized below:

Filament Wound Pipe Design

RPS A150 and P150 piping have internal pressure ratings based on ASTM D2992. This standard provides two methods for determining the “Hydrostatic Design Basis” or “HDB”, which is the hoop stress (or strain) that provides an estimated life of 100,000 hours (per the static test method) or 150 million cycles (per the cyclic test method). The static test method involves subjecting numerous samples of piping to various levels of stress such that failures occur in both the short term and long term (10,000 hours maximum). The data is then plotted on a logarithmic scale, and extrapolated to 11.4 years and 50 years to determine the HDB. Similarly, the cyclic method tests samples for up to 15 million cycles, and the data is extrapolated to 150 million cycles to determine the HDB. A service factor equal to 1.0 or less for the cyclic method and 0.5 or less for the static method is then applied to the HDB to determine the corresponding pressure rating or hydrostatic design strength (HDS).

With the hydrostatic design strength, the required wall thickness can be calculated using the ISO formula, as follows:

$$\text{Structural Thickness} = \frac{\text{Pressure} \times \text{Diameter}}{2 \times \text{HDB} \times \text{Service Factor}}$$

or

$$\text{Structural Thickness} = \frac{\text{Pressure} \times \text{Diameter}}{2 \times \text{HDS}}$$

For piping, which does not have an HDB rating, the structural wall thickness is based on the short term burst strength (determined in accordance with ASTM D1599).

This provides a conservative estimate of the required wall thickness, calculated as follows:

$$\text{Structural Thickness} = \frac{\text{Pressure} \times \text{Diameter} \times \text{FOS}}{2 \times \text{hoop strength}}$$

where,

Pressure = Design pressure of the system

Diameter = Inside pipe diameter

FOS = Required factor of safety (typically 6 to 10)

Hoop strength = Short term hoop strength, typically 40,000 psi for pipe wound at 55°)



Corrosion Barrier Addition: The corrosion barrier (liner) is generally added to the thickness calculated above, as follows:

$$t_{\text{total}} = t_{\text{liner}} + t_{\text{structure}}$$

However, in less aggressive environments, the designer may choose to include the corrosion barrier (or some portion thereof) in the structural calculations.

In some cases, the structural thickness may be increased to accommodate other factors such as vacuum or stiffness requirements. Small diameter adhesively bonded piping may also have increased thickness to provide adequate bond length in the joint.

Diameter**	Filament Wound Pipe Wall Thickness* (in.)				
	Butt Joint System			Adhesive Joint System	
	150 psi Total Thickness	100 psi Total Thickness	50 psi Total Thickness	150 psi Total Thickness	100/50 psi Total Thickness
1	0.19	0.19	0.19	0.19	0.19
1.5	0.19	0.19	0.19	0.19	0.19
2	0.19	0.19	0.19	0.19	0.19
3	0.19	0.19	0.19	0.19	0.19
4	0.19	0.19	0.19	0.20	0.20
6	0.22	0.19	0.19	0.24	0.24
8	0.26	0.21	0.19	0.28	0.24
10	0.30	0.24	0.19	0.32	0.27
12	0.34	0.26	0.19	0.37	0.31
14	0.37	0.29	0.20	N/A	N/A
16	0.41	0.31	0.21	N/A	N/A
18	0.45	0.34	0.22	N/A	N/A
20	0.49	0.36	0.24	N/A	N/A
24	0.56	0.41	0.26	N/A	N/A
30	0.67	0.49	0.30	N/A	N/A
36	0.79	0.56	0.34	N/A	N/A

* Includes 0.11" *non-structural* Corrosion Barrier

** See Dimensional Catalogue for exact ID's. Contact RPS for pipe and fitting OD's. Fitting OD's will be considerably greater than pipe OD's.



Contact Molded Pipe and Fitting Design

The design of contact molded pipe and fittings is based on the short term ultimate strength properties of the liner and structural layers. The design method involves calculating the total number and type of reinforcing layers required rather than an overall thickness. Based on in-house testing and industry standards, the short-term unit strength of the various types of reinforcement used at RPS has been determined. This is compared with the overall strength required per the ISO formula. Factors of Safety (FOS), typically in the range of 6 to 10, are applied to the stress calculation.

Example: 6"φ 150 psi, contact molded pipe with 10:1 FOS

$$\text{Unit Hoop Stress} = \text{Pressure} \times \text{diameter} \times \text{FOS} / 2$$
$$= 150 \times 6 \times 10 / 2 = 4500 \text{ lb/in.}$$

$$\text{Unit Axial Stress} = \text{Pressure} \times \text{diameter} \times \text{FOS} / 4$$
$$= 150 \times 6 \times 10 / 4 = 2250 \text{ lb/in.}$$

A variety of possible reinforcements could be used to meet these requirements. However, a trial and error approach is generally required. For example, if this pipe were to be constructed from 1.5 oz/ft² chopped strand and 24 oz/yd² woven roving, the following combination could be used:

4 layers of chopped strand @ 600 lb/in. = 2400 lb/in.
2 layers of woven roving @ 1250 lb/in. = 2500 lb/in.

$$\text{Total Strength} = (2400 + 2500) = 4900 \text{ lb/in.}$$

This would satisfy both the hoop and axial strength requirements.

Pressure Stress Multipliers and Fitting Design

Many fittings are subject to higher pressure stress than the ISO formula would indicate due to their geometric configuration. For example, size on size tees typically have a pressure stress of approximately 2 times that of the same diameter pipe. To compensate for this, the designer should include "pressure stress multipliers" (PSM) in the ISO equation.

$$\text{Unit Hoop Stress} = \text{Pressure} \times \text{Diameter} \times \text{FOS} \times \text{PSM} / 2$$

By not including a pressure stress multiplier (PSM) in the stress calculation, the true factor of safety is reduced. Therefore, the appropriate multiplier should be calculated and included in the fitting design. It should be noted that the above mentioned increased stress may only be localized, and thus, the reinforcement required to compensate for the

effect *may* also only need to be localized. This needs to be examined on a case by case basis and may require hydrostatic testing and/or finite element analysis for verification.

The nature of fitting construction and the effect of the pressure stress multiplier results in fittings which may be considerably thicker than the adjoining pipe, particularly in the case of tees. This needs to be considered with respect to clearances with structural steel and other pipe lines or equipment.

Design for Vacuum



Very often, thin-walled piping, and particularly ducting, must be designed to handle vacuum loads. The resistance to vacuum is related to the stiffness of the pipe or duct,

which is related to the thickness and modulus of elasticity. Generally, the design for vacuum service follows two approaches.

Low to Moderate Vacuum Rating / Small Diameters:

- Increase wall thickness to provide required collapse pressure.

High Vacuum Requirements / Large Diameters:

- Use Stiffening Ribs to provide required collapse pressure

The decision to use stiffening ribs is generally a question of economics. That is, stiffening ribs are used at the point when the cost associated with the required increase in pipe wall thickness exceeds the cost of applying the ribs.

For pressure piping, vacuum resistance is generally achieved through increased wall thickness as the application of ribs could create high local stresses when the pipe operates under pressure.

The collapse pressure of pipe or ducting is calculated based on the "Structural Plastic Design Manual" equations.

For Pipe/Duct without ribs

(assumed to be an infinitely long cylinder)

$$P_{cr} = \frac{E_h t^3}{4 \cdot (1 - \nu_{TL} \cdot \nu_{LT}) \cdot R^3}$$



Where,

E_h = Hoop flexural modulus of pipe/duct

t = Wall thickness of pipe/duct

ν_{TL} = Poisson's ratio for hoop stress causing axial strain

ν_{LT} = Poisson's ratio for axial stress causing hoop strain

R = Pipe/Duct outside radius

For Pipe/Duct with ribs

$$P_{cr} = \frac{5.5 \cdot k_n \cdot A_x^{1/4} \cdot D\theta^{3/4}}{L \cdot R \cdot \sqrt{R}}$$

Where,

k_n = "knockdown factor" = 0.9

$A_x = E_a \cdot t$

$$D\theta = \frac{E_h \cdot t^3}{12 \cdot (1 - (\nu_{TL} \cdot \nu_{LT})^2)}$$

E_a = Axial tensile modulus of pipe/duct (psi)

L = Length between ribs (in.)

R = Pipe/Duct outside radius



Corrosion Barrier Addition: The corrosion barrier (liner) is generally added to the thickness calculated above, as follows:

$$t_{total} = t_{liner} + t_{structure}$$

However, in less aggressive environments, the designer may choose to include the corrosion barrier (or some portion thereof) in the structural calculations. However, the composite properties (i.e Hoop Modulus of total wall, Poisson Ratio's of total wall, etc.) must be determined and used in the calculations. This is particularly important in vacuum design since the collapse pressure is related to the thickness cubed ($P_{critical} \propto t^3$)

ABOVE GROUND PIPING SYSTEM DESIGN



The design of piping systems using RPS piping, or most other FRP piping, differs from steel piping system design. The differences in design are related to the differences in mechanical and physical properties between FRP and steel. Some important points to consider are summarized below:

Differences between FRP and Steel

FRP has greater flexibility than steel. ($E_{FRP} \approx 1/20^{th} E_{steel}$).	<ul style="list-style-type: none"> - Requires closer support spacing. - Larger oscillations occur more easily. - Earlier column failure possible. - Loads on supports are lower for a given amount of expansion
FRP has a lower longitudinal strength than steel	<ul style="list-style-type: none"> - Requires closer support spacing. - Requires support of heavy valves. - Requires prevention of severe water hammer. - Longitudinal loads are relatively more important.
FRP does not yield (no plastic deformation)	<ul style="list-style-type: none"> - Stress concentrations and point loads must be avoided.
Cold Temperature Design	<ul style="list-style-type: none"> - Most properties including impact resistance remain unchanged for temperatures down to -50 deg. F



Differences between FRP and Steel Cont'd

FRP has a greater coefficient of thermal expansion (about 2.5 times steel).	- Requires greater allowance for movement.
Strength and rigidity drop rapidly above 200 deg. F.	- Careful design needed at high temperatures. - Hot spots must be avoided.
Creep	- FRP will creep under long term steady load however this will vary greatly with fiber orientation. The high safety factors used in FRP design (typically 6 to 10) generally account for this.

Note:
FRP fittings may be significantly thicker than the adjoining FRP pipe. Give careful consideration to clearances in tight areas.

General Recommendations and Comments on FRP Piping Systems Design

- ❑ Give early consideration to supports since FRP piping generally requires closer support spacing than steel piping.
- ❑ FRP piping is flexible and undesirable longitudinal oscillations can occur at pump start-up etc.. To prevent this, anchor each straight leg once, and only once.
- ❑ Control side-ways oscillations by replacing every fourth hanger with a guide
- ❑ All clamps, hangers and anchors should have an 1/8" rubber lining to prevent chafing of the FRP and provide a uniform contact surface
- ❑ Expansion joints should be used sparingly (see pg. 19 for more detail)
- ❑ Do not rely on friction for support of risers and anchors, use FRP thrust collars
- ❑ Friction clamps should only be relied on to support or resist very small longitudinal loads, when in doubt use FRP thrust collars.
- ❑ Include guides as required to prevent column-type buckling failure (see ahead for more detail)

- ❑ Heavy valves must be supported independently
- ❑ Water-hammer must be minimized
- ❑ Incorporate field joints generally at each change of direction. Keep in mind that FRP flanges should not be "drawn" into place and should freely line-up.
- ❑ Avoid bolting full face FRP flanges to raised face flanges. Use FRP Vanstone style flanges or spacers as required.
- ❑ For other than flange supports, avoid locating supports at or adjacent to fittings. Allow enough room between the support and the fitting for the joint overlay.

Recommended Hanger Spacing

Note: Refer also to information on guide spacing to prevent column-type buckling (page 19).

SUPPORT SPACING (ft.) @ 150 deg. F* for RPS P150 & A150 piping				
Diameter	Single Span		Continuous Span	
	SG =1.0	SG =1.3	SG =1.0	SG =1.3
1	7.0	7.0	9.0	9.0
1-1/2	7.3	7.1	9.3	8.7
2	8.0	7.5	9.8	9.2
3	8.4	7.7	10.3	9.5
4	8.7	8.0	10.7	9.8
6	10.9	10.0	13.3	12.2
8	10.9	10.0	13.1	12.0
10	13.0	11.6	15.6	13.9
12	13.7	13.0	16.4	15.6
14	13.7	13.0	16.4	15.6
16	15.2	14.0	18.2	16.8
18	16.7	15.0	20.0	18.0
20	17.4	15.5	20.9	18.6
24	19.1	17.0	22.9	20.4
30	20.5	18.3	24.6	22.0
36	22.1	19.7	26.5	23.6

Criteria: Strength Ratio (SR) in structure > 1.6
Deflection < 0.50"

* For 180 deg. F service, derate span by **0.90**



For information on support spacing for pressure ratings, specific gravities, or diameters other than those listed above, please contact RPS directly.



Pipe Supports

Supports for RPS FRP piping should be designed with the principles mentioned in the previous sections borne in mind. For example, the supports should ensure point loading of the pipe does not occur, and they should ensure there is no chafing or abrasion between the pipe and the support. A complete line of standard supports suitable for RPS FRP piping is included in the RPS Pipe Support Catalog. The type of support to use for a specific application will depend upon a number of factors, the most important of which are the intended function of the support and the configuration of the available structural steel. The basic types of supports are weight supports, guides, and anchors. Various configurations of each of these types of supports are shown in the RPS Pipe Support Catalog. The choice of which type of weight support to use for example, would depend on whether the pipe will be supported from underneath the pipe, or from above the pipe. In the first case, a Slide Shield, a Flange Slide, or a Base Slide would all be suitable support types. In the latter case, a Clamp or Clevis Hanger would be appropriate choices.

The supports shown in the RPS Pipe Support Catalog are standard types of supports only. Custom-designed supports are also available as required to suit particular project requirements. Please contact RPS for further information.



Thermal Expansion Design

FRP piping will expand when heated. The amount of expansion that occurs depends on:

- The difference between the maximum operating and installed temperatures
- The coefficient of thermal expansion (which typically equals 1.4×10^{-5} in/in/deg.F for RPS piping)
- The length of pipe that is free to expand

To deal with thermal expansion, the designer generally follows one of two approaches:

- Create a semi-rigid support system
- Create a rigid (anchored) support system

These two types of approaches are explained in more detail below.

Semi-Rigid Piping System

As mentioned above, FRP will *want* to expand when heated. If the piping is totally free to expand, it will do so, and no stress will be introduced into the piping system as a result of the temperature change. However, this is not normally the case as changes in direction and pipe supports generally provide some resistance to expansion. This creates stress in the piping and introduces forces on the supports. By controlling the length of straight runs of piping and the length of off-set legs, the designer can most generally control the thermal expansion. The two basic principals that must be satisfied are:

- Provide sufficient support to carry the self weight of the pipe and other loads such as wind and snow.
- Provide enough flexibility to absorb thermal expansion

These two principals are often in conflict with one another, which can make the design process a trial and error procedure. The recommended hanger spacings, listed at the start of this section, provide sufficient support for self weight. The most common method of providing the required flexibility in the system is with changes in direction or offset legs. It should be noted, however, that the change in direction should generally be at an elbow, not at branch connections such as tees or saddles.



The required length of an offset leg can be calculated as follows:

$$L_{leg} = 1/12 \cdot \{ 3 \cdot E \cdot I \cdot \Delta L / M \}^{0.5} \text{ (ft.)}$$

Where,

E = Axial Modulus of elasticity

I = Moment of Inertia of total wall
 $= \pi/64 (OD^4 - ID^4)$

ΔL = Change in length = $C_e \cdot L_f \cdot \Delta T$

and

C_e = Coefficient of thermal expansion

L_f = Length from anchor

ΔT = Difference between max. operating and installed temperatures

M = Allowable Bending Moment = $S_b \cdot Z_s$

and

S_b = Allowable bending stress

Z_s = Section Modulus of structure
 $= 2 \cdot I_s / OD$

I_s = Moment of Inertia of structure
 $= \pi/64 (OD^4 - (ID+2 \cdot t)^4)$

Example: What is the required offset length for the given piping arrangement and parameters?

OD = 8.52 in. T = 0.26 in. Ts = 0.15 in.
 $S_b = 650 \text{ psi}$ E = 1.29e6 psi
 $L_f = 24 \text{ ft.} = 288 \text{ in.}$ $\Delta T = 100 \text{ deg. F}$
 $C_e = 1.4 \times 10^{-5} \text{ in/in/deg.F}$

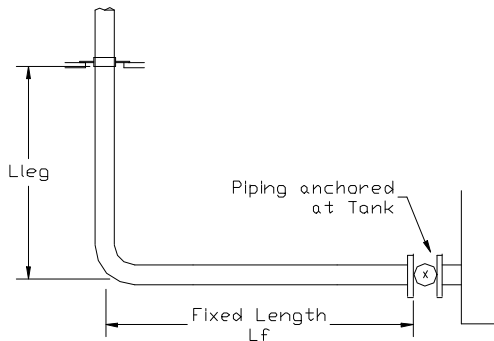

Solution:

$$I_{total} = \pi/64 \cdot (8.52^4 - 8.0^4) = 57.6 \text{ in}^4$$

$$\Delta L = 1.4 \times 10^{-5} \cdot 288 \cdot 100 = 0.40 \text{ in.}$$

$$I_{struct} = \pi/64 \cdot (8.52^4 - (8.0+0.11 \times 2)^4) = 34.5 \text{ in}^4$$

$$Z_{struct} = 2 \cdot I_s / OD = 2 \cdot 34.5 / 8.52 = 8.1 \text{ in}^3$$

$$M_{allow} = S_b \cdot Z_s = 650 \times 8.1 = 5265.0 \text{ in-lb}$$

Therefore,

$$L_{leg} = 1/12 \cdot \{ 3 \cdot 1.29E6 \cdot 57.6 \cdot 0.40 / 5265.0 \}^{0.5} = 10.85 \text{ ft.}$$

This is the *minimum* offset that should be used to ensure the bending stress in the piping is maintained at an acceptable level.



Corrosion Barrier Addition: When calculating thermal forces and stresses, it is very important to consider the effect of the corrosion barrier. This is summarized below:

- The thermal force should be calculated based on the total wall area (i.e include the corrosion barrier in this calculation).
- The *composite* modulus should be used to calculate the thermal load. However, since the structural modulus is generally slightly higher, the structural modulus can be used to provide a slightly more conservative result.
- The structural wall area should be used to determine the pipe stress resulting from the thermal force. In some less aggressive environments, the designer may choose to consider the contribution of the corrosion barrier (or some part thereof) for the stress calculation.

ID	Laterally Free Length Required at Elbow*						
	Expansion (in.)						
	0.2	0.4	0.6	0.8	1	2	4
1	1.9	2.7	3.3	3.8	4.2	5.9	8.4
1.5	2.3	3.3	4.0	4.6	5.2	7.3	10.3
2	2.8	4.0	4.9	5.7	6.4	9.0	12.7
3	4.0	5.7	6.9	8.0	8.9	12.6	17.9
4	5.3	7.4	9.1	10.5	11.8	16.6	23.5
6	5.9	8.3	10.2	11.7	13.1	18.6	26.3
8	7.7	10.9	13.4	15.5	17.3	24.4	34.6
10	8.4	11.9	14.6	16.9	18.8	26.7	37.7
12	9.1	12.8	15.7	18.1	20.3	28.7	40.6
14	9.7	13.7	16.7	19.3	21.6	30.6	43.2
16	10.3	14.6	17.8	20.6	23.0	32.6	46.0
18	10.8	15.3	18.7	21.6	24.2	34.2	48.4
20	11.3	16.0	19.6	22.7	25.3	35.8	50.6
24	12.2	17.3	21.1	24.4	27.3	38.6	54.6
30	13.4	19.0	23.2	26.8	30.0	42.4	60.0
36	14.6	20.6	25.2	29.1	32.6	46.1	65.2

* When the offset leg terminates at a flange or tee, the free length should be increased by 20%.



Semi-Rigid Piping System Cont'd

Expansion Loops

When changes in direction are not possible or practical, the designer may want to consider creating an **expansion loop** in the system to absorb the thermal growth and force. The length of the loop will be the same as the free leg length calculated in the above example. The axial portion of the loop is normally taken as 1/2 of the leg length. Guides should be included immediately upstream and downstream of the expansion loop.

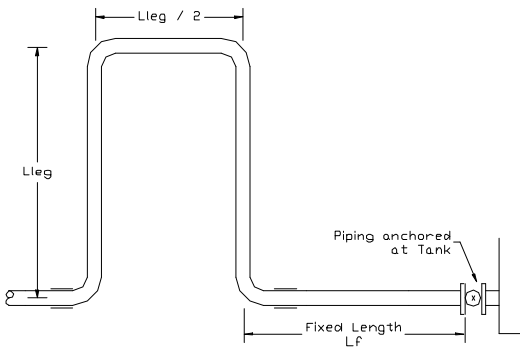

Rigid Piping System

An alternative to the semi-rigid piping system is the rigidly restrained piping system. With this system, thermal expansion is prevented by anchoring the pipe in various locations. The corresponding forces are transferred into the support structure and the piping itself. This system is possible due to the low elastic modulus of FRP in comparison to steel. As demonstrated in the example calculation, the low elastic modulus creates forces which are often easily handled by the support structure.

$$\text{Force} = E \cdot A \cdot Ce \cdot \Delta T$$

Where:

- E = Axial modulus of elasticity
- A = Cross sectional Area of piping
- Ce = Coefficient of thermal expansion
- ΔT = Difference between operating and installed temperature

Example Part A: What is the thermal force at anchor #1 for the given piping arrangement?

- OD = 6.48 in.
- ID = 6.00 in.
- Ce = 1.4 x 10⁻⁵ in/in/deg.F
- E = 1.5e6 psi
- ΔT = 50 deg. F

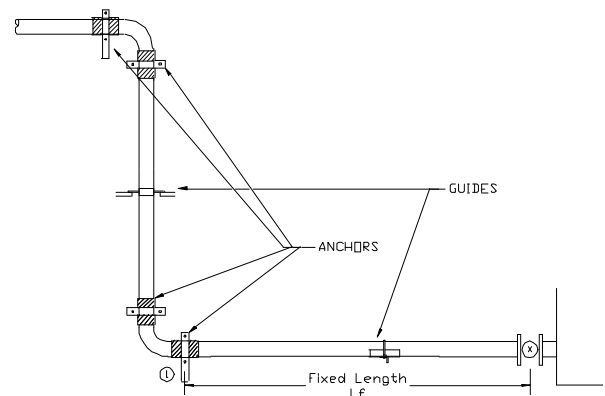

Solution:

$$\text{Area} = \pi \cdot (6.48^2 - 6.00^2) / 4 = 4.70 \text{ sq.in.}$$

$$\text{Force} = 1.5 \times 10^6 \cdot 4.70 \cdot 1.4 \times 10^{-5} \cdot 50 = 4,940 \text{ lbs}$$

Note: this is the actual force and does not include a design factor (or factor of safety).

Example Part B: What is the stress on the piping given the above anchoring force.

Solution:

$$\text{Stress} = \text{Force} / \text{Structural Area}$$

Where,

$$\text{Structural Area} = \pi \cdot (6.48^2 - 6.22^2) / 4 = 2.59 \text{ sq.in.}$$

$$\text{Stress} = 4940 \text{ lbs} / 2.59 \text{ sq.in.} = 1905 \text{ psi}^*$$

*Note: This is the stress on the structural wall assuming a 0.11" thick corrosion liner.



Guide Spacing and Column-type Bucking

In the general recommendations for supporting FRP piping is was pointed out that every 4th hanger should be replaced by a guide to prevent unwanted oscillations. However, guides are also required to prevent column-type buckling in a rigid system. This is demonstrated in the example below:

Example: Determine the required hanger and guide spacing for the rack piping shown below. As shown in the sketch, the piping is rigidly restrained at the valve and at the change in direction.

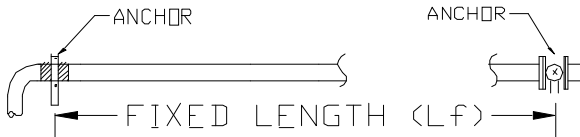

- OD = 6.48 in.
- ID = 6.0 in.
- Ce = 1.4 x 10⁻⁵ in/in/deg.F
- E = 1.5e6 psi
- ΔT = 50 deg. F
- Lf = 100 ft.

Solution: The support spacing must first be determined. For RPS 6"Ø, 150psi rated piping, the maximum support spacing would be 10.9' (see "Recommended Hanger Spacing Table")

$$\text{Support Spacing} \leq 10.9 \text{ feet}^*$$

* This could be increased to 13.3' after three (3) simple supports since the arrangement would be considered a continuous support.

The thermal force on the anchor would be:

$$\text{Force} = E \cdot A \cdot Ce \cdot \Delta T$$

where, Area = $\pi \cdot (6.48^2 - 6.00^2) / 4 = 4.70 \text{ sq.in.}$

$$\text{Force} = 1.5 \times 10^6 \cdot 4.70 \cdot 1.4 \times 10^{-5} \cdot 50 = 4,940 \text{ lbs}$$

The guide spacing depends on the critical buckling load of the piping arrangement calculated as follows:

$$P_{\text{critical}} = \pi^2 \cdot E \cdot I / L^2$$

The equation can be re-arranged to solve to L (the critical buckling length)

$$L_{\text{critical}} = (\pi^2 \cdot E \cdot I / P_{\text{applied}})^{1/2}$$

Where,

$$\begin{aligned} E &= \text{Axial modulus of pipe} = 1.5 \text{ e } 6 \text{ psi} \\ I &= \text{Moment of inertia of cross section} \\ &= \pi/64 \cdot (\text{OD}^4 - \text{ID}^4) \\ &= \pi/64 \cdot (6.48^4 - 6.0^4) = 22.93 \text{ in}^4 \end{aligned}$$

$$P_{\text{applied}} = \text{Applied compressive force} = 4940 \text{ lbs.}$$

$$\begin{aligned} L_{\text{critical}} &= (\pi^2 \cdot 1.5\text{e}6 \cdot 22.93 / 4940)^{1/2} \\ &= 262 \text{ in} = 21.8 \text{ feet} \end{aligned}$$

Therefore, for this example, every second support (which were required at approximately 10' intervals) should be replaced by a guide to prevent column-type buckling.

Expansion Joint Use and Design



In some situations, it is not possible or practical to deal with expansion using changes in direction or expansion loops and/or the forces associated with a rigid system are too high for the piping or supports. In these situations, expansion joints can be used to absorb thermal growth. Some general comments regarding expansion joints and FRP piping are summarized below:

- Expansion joints are not normally required on small bore FRP piping systems as they are generally inherently flexible.
- Expansion joints may be required to absorb large differential expansion between, for example, steel tanks and FRP piping.
- Expansion joints may be used to isolate the FRP piping system from vibrating equipment such as large pumps or fans.
- When choosing expansion joints, the designer needs to consider that the required activation force needs to be smaller than would normally be suitable on similar diameter steel piping.
- The use of tie-rods or limiting rods should be avoided if possible as these act to concentrate forces on the FRP flange and could result in damage to the FRP flange. If tie-rods are necessary, the FRP flange may require a steel backing ring to better distribute the pressure load.



Pipe Stress Analysis and Allowable Stresses

An ever increasing number of companies are choosing to design and analyze their piping systems using computerized pipe stress analysis programs. These programs can quickly provide the user with information on deflections, stresses and forces. Below are some general tips for analyzing RPS FRP piping using computerized analysis programs.

- An easy, yet accurate and conservative way to analyze FRP piping is to input a total wall thickness and a corrosion allowance. This will allow the program to calculate forces and weights based on the total wall but determine stress based on the structural or corroded wall. The inputs should be based on composite wall properties, keeping in mind the following:
- Different modulus values are required for each diameter or diameter range.
- Different coefficients of thermal expansion are required for each diameter or diameter range.
- Different Poisson's ratios are required for each diameter or diameter range.
- The same allowable stress can be used for all sizes, since the analysis is based on the structural wall only.

TIP - Consider setting-up a computer spreadsheet to quickly calculate the composite pipe properties for the required diameters!

- Consider entering the "maximum operating pressure" rather than the "rated pressure". Very often companies purchase, for example, 150 psi rated piping, and use the piping for low pressure or even gravity feed. By using the maximum operating pressure in the pipe stress analysis, the user may be able to solve many stress problems.
- Stress analysis without a corrosion allowance (i.e. including some contribution of the corrosion barrier in the stress calculations) requires different allowable stresses for different diameter ranges, since the corrosion barrier will contribute less and less structurally as the diameter increases. This makes the analysis more complex and the designer should contact RPS directly for more information on this approach.

Allowable Stresses

RPS piping is filament wound and highly orthotropic in nature. In particular, the piping has different strength values related to pressure and bending.

For stress analysis based on the structural wall only (i.e. total thickness less the corrosion allowance). The following allowable stresses apply:

Table with 3 columns: Allowable Stress, Diameter, and Value. Values range from 2650 psi to 2550 psi for diameters from 1" to >12".

Table with 3 columns: Allowable Stress, Diameter, and Value. Values are 2650 psi for 1" and 2000 psi for >1".

(Use linear interpolation for all pressures in between 0 and 150 psi)

Example: What is the allowable stress of 4"Ø RPS 150 psi rated piping operating at 80 psi?

Allowable stress at 80 psi = 80 * ((2350-2000)/(150-0)) + 2000 = 2082 psi

The above mentioned allowable stresses provide a combined factor of safety of 6 to 1

Note:

- 1. Many codes require the use of a "hot" and "cold" allowable stress; however the allowable stress for FRP piping applies to both the "hot" and "cold" allowable.
2. The analysis of thermal loads as separate from other loads such as pressure and weight is not appropriate for FRP piping. The stresses resulting from the combined loads, including thermal loads, must comply with the allowable stresses.
3. Allowable stresses for elbows are typically different than for filament wound pipe. The following values can be used:

Table with 3 columns: Allowable Stress, Diameter, and Value. Values range from 2700 psi to 2425 psi for diameters from 8" to >24".

Table with 3 columns: Allowable Stress, Diameter, and Value. Values range from 3300 psi to 2200 psi for diameters from 1" to >24".



Stress Intensification Factors (SIF's)

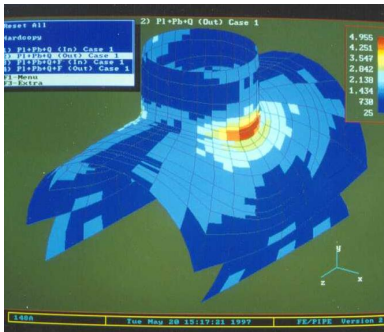

Proper pipe stress analysis requires an understanding of stress intensification factors (SIF's). These factors are required to account for the increased bending stresses that occur in fittings as compared to

straight pipe. Exact determination of SIF requires testing and/or finite element analysis. Typical SIF's are listed below. Please contact RPS for additional information.

Elbows (150 psi Rated)	
ID	SIF
1	1.5
1.5	1.5
2	2.0
3	2.0
4	2.0
6	2.0
8	3.0
10	3.0
12	3.0
14	3.4
16	3.5
18	3.7
20	3.7
24	3.8
30	4.0
36	4.1

**Reducing Branches
(150 psi Rated)**

d/D *	SIF
≥ 0.5	2.3
≤ 0.2	1.5

*Use linear interpolation between these values

**Tee's & Laterals
(150 psi Rated)**

ID	SIF
≤ 12"	2.3
> 12"	2.5

General Comments on SIF's

- SIF's will generally be higher than those listed for fittings with a lower pressure rating.
- The flexibility factor (k) for FRP fittings is often assumed to be 1.0. For larger diameter piping (eg. > 12" diameter), and for thin-walled piping, it may be helpful to take advantage of the inherent flexibility of elbows. More accurate values for the flexibility factor of these elbows can be calculated from:

$$K = 0.6 / h$$

where,

$$h = \frac{\text{Elbow thickness} \cdot \text{Bend radius}}{(\text{Diameter} / 2)^2}$$



BURIED PIPE DESIGN & INSTALLATION



FRP piping is considered to be flexible pipe and the design relies on the passive support of the soil around the pipe to resist loads from above.

Therefore the designer needs to appreciate that

the proper installation of buried FRP piping is at least as important as a proper design.

Buried Pipe Design

The design of buried FRP piping generally follows the guidelines of the American Water Works Association document AWWA M45. This manual supersedes the design information previously presented in AWWA C950. Buried pipe deflection is predicted using the Spangler equation which combines material properties with soil properties and live loads to predict an overall deflection.

$$\frac{\Delta y}{D} = \frac{(D_f \cdot W_c + W_L) \cdot K_x}{0.149 \cdot PS + 0.061 \cdot E'} \quad (\text{deflection})$$

where,

D_f = Deflection Lag factor (typically 1.5)

W_c = Vertical soil load = $\gamma_s \cdot H / 144$, psi

and

γ_s = Unit weight of overburden, lb/ft³

H = Burial depth to top of pipe, ft

W_L = Live load on pipe = $P \cdot I_f / (144 \cdot L_1 \cdot L_2)$, psi

and

P = wheel load = 16,000 lbs for HS-20

I_f = Impact factor
 = 1.1 for $2' < H < 3'$
 = 1.0 for $H \geq 3'$

L_1 = load width parallel to direction of travel
 = $0.83 + 1.75 H$

L_2 = load width in direction perpendicular to travel
 = $1.67 + 1.75H$ for $2' < H < 2.48'$
 = $(43.67 + 1.75H)/8$ for $H \geq 2.48'$

K_x = Bedding coefficient = 0.083 to 0.1

PS = Pipe stiffness = $EI / \{0.149 (r + \Delta y/2)^3\}$

E' = Modulus of soil reaction, psi
 (depends on soil type and compaction)

The designer can examine the effects of the deflection in terms of stress or strain by using an empirical equation, which has been shown to provide a good correlation between field measurements and experimental results:

$$\sigma_b = D_f \cdot E' \cdot \left(\frac{\Delta y_a}{D} \right) \left(\frac{t_f}{D} \right) \quad (\text{stress due to deflection})$$

$$\epsilon_b = D_f \cdot \left(\frac{\Delta y_a}{D} \right) \left(\frac{t_f}{D} \right) \quad (\text{strain due to deflection})$$

where,

D_f = Shape factor based on soil and pipe stiffness

E = Ring flexural modulus, psi

Δy_a = Maximum allowable long term deflection, in.

t_f = Pipe total wall thickness, in.

D = Mean pipe diameter, in.

These values are compared with the long term ring bending strain divided by a design factor.

$$\sigma_b \leq \frac{S_b \cdot E}{FS}$$

or

$$\epsilon_b \leq \frac{S_b}{FS}$$

where,

S_b = Long term ring bending strain

FS = Design factor = 1.5



The effects of pressure also need to be examined and the pressure class of the piping determined based on the HDB.

for stress basis,

$$P_c \leq \{HDB/FS\} \cdot \{2 \cdot t/D\}$$

for strain basis,

$$P_c \leq \{HDB/FS\} \cdot \{2 \cdot E_h \cdot t / D\}$$

where,

P_c = Pressure class, psi

HDB = Hydrostatic design basis (psi for stress basis and in/.in for strain basis)

FS = Minimum design factor = 1.8

t = Thickness of pipe reinforced wall, in.

D = Mean diameter of pipe, in.

E_h = Hoop tensile modulus, psi

The working pressure must be less than the pressure class denoted as:

$$P_w \leq P_c$$

The surge pressure should be less than:

$$P_s \leq 1.4 \cdot P_c - P_w$$

The effects of combined loading of pressure and bending are also examined and evaluated as follows:

for stress basis,

$$\frac{\sigma_{pr}}{HDB} \leq \frac{1 - \{(\sigma_b \cdot rc) / (S_b \cdot E)\}}{FS_{pr}}$$

and

$$\frac{\sigma_b \cdot rc}{S_b \cdot E} \leq \frac{1 - \{\sigma_{pr} / HDB\}}{FS_b}$$

for strain basis,

$$\frac{\epsilon_{pr}}{HDB} \leq \frac{1 - \{(\epsilon_b \cdot rc) / S_b\}}{FS_{pr}}$$

and

$$\frac{\epsilon_b \cdot rc}{S_b} \leq \frac{1 - \{\epsilon_{pr} / HDB\}}{FS_b}$$

where,

FS_{pr} = Pressure design factor = 1.8

FS_b = Bending design factor = 1.5

σ_{pr} = Working stress due to pressure, psi
= P_w · D / 2 · t

σ_b = Bending stress due to max. deflection, psi
= D_r · E · (δ_d/D) · (t/D)

rc = Rerounding coefficient due to internal pressure

ε_{pr} = Working strain due to internal pressure
= P_w · D / (2 · t · E_h)

ε_b = Working strain due to max. deflection
= D_r · (δ_d/D) · (t/D)

δ_d = Maximum permitted long term installed deflection, in.

The possibility of buckling also needs to be examined with the allowable buckling pressure calculated as follows:

$$q_a = (1/FS) \{ 32 \cdot R_w \cdot B' \cdot E' \cdot EI / D^3 \}^{1/2}$$

where,

FS = Design factor = 2.5

R_w = Water buoyancy factor
= 1 - 0.33 (h_w/h) ≥ 0

and

h_w = Height of water above pipe, ft.

B' = Empirical coefficient of elastic support
= 1 / (1 + 4e^{-0.065H})

h ≈ H = Height of soil above pipe, ft.

E' = Modulus of soil reaction, psi

This equation is valid for:

2' ≤ H ≤ 80' without vacuum

4' ≤ H ≤ 80' with vacuum



The allowable buckling pressure is compared with the applied buckling loads as follows:

$$\gamma_w \cdot h_w + R_w \cdot W_c + P_v \leq q_a$$

where,

$$\gamma_w = \text{Specific weight of water} = 0.0361 \text{ lb/in}^3$$

P_v = Internal vacuum pressure, psi

When live loads are present, this should be examined separately. The simultaneous effect of live load and internal vacuum need not typically be considered.

$$\gamma_w \cdot h_w + R_w \cdot W_c + W_L \leq q_a$$

Buried Pipe Installation

As mentioned at the start of this section, the installation of buried pipe is at least as important as the proper design of the piping. Below is a summary of some of the important points to consider when installing buried FRP piping.

- ◆ The initial excavation should encompass the pipe diameter plus 6" to 12" below the pipe and at least 12" on either side. The side walls should be adequately sloped or safely supported.
- ◆ The bedding should consist of at least 6" of well graded, granular material (ex. sand or gravel) which will allow for drainage of ground and surface water under the piping. This material should be slightly shaped to accept the contour of the pipe and well compacted to at least 98% Proctor Density. All large rocks should be removed and any soft spots in the native soil should be excavated and re-filled.
- ◆ The "haunches" of the pipe need to be well supported with the above mentioned fill and the fill must be well compacted (typically >98% Proctor) using hand equipment and small machinery.
- ◆ The remainder of the fill in the pipe-zone should be placed in reasonable lifts (typically 6" at a time) and must be well graded to allow for proper drainage and well compacted (typically > 98% Proctor) to provide support for the pipe side walls. Care must be taken, however, to ensure the piping does not go out of round during backfilling & compacting.

- ◆ In-situ or native soil can generally be applied in 12" lifts to fill outside of the pipe zone. The top layer of the material should be stabilized to prevent erosion.
- ◆ Do not pass spreading equipment directly over the pipe until 4' of fill has been placed over the crown.
- ◆ Groundwater should be redirected away from the buried pipe using culverts or swales.
- ◆ FRP piping is lightweight and, when empty, will float-out of its bedding if surface and ground water are not properly redirected. Once the piping has "floated" it must be reinstalled.
- ◆ For severe traffic loads such as at railway crossings, the FRP piping should be concrete encased.
- ◆ Use a flexible gasket to protect the outside of the buried pipe where it passes through a concrete wall.
- ◆ Watch for differential soil movement where buried pipe passes through walls.
- ◆ If O-ring joints are used, concrete thrust blocks are required at significant changes in direction.
- ◆ For O-ring joints, remove material under the spigot to lessen the chance of foreign material entering the bell during insertion.
- ◆ If butt and wrap joints are used, the area under the joint must be sufficiently excavated to allow the worker to apply and roll-out the reinforcing material.

RPS is also experienced in the design of partially buried piping. This design and installation method can provide reduced wall thickness compared to fully buried piping due to the reduction of soil loading. It is critical, however, that well compacted soil be placed around the piping sufficient to hold the piping in place and maintain roundness.

References

For more information on buried piping design and installation refer to:

RPS Pipe & Fittings Installation Manual

American Water Works Association - "Fiberglass Pipe Design – AWWA M45"

"Standard Practice for Underground Installation of Fiberglass Pipe – ASTM D 3839" – ASTM Standard



JOINING SYSTEMS



RPS utilizes four (4) major types of joining systems on our products. The designer needs to carefully examine each system to determine which best

suits the particular application. A description of each joining system from a design standpoint is provided below:

RPS TAPERED ADHESIVE JOINT

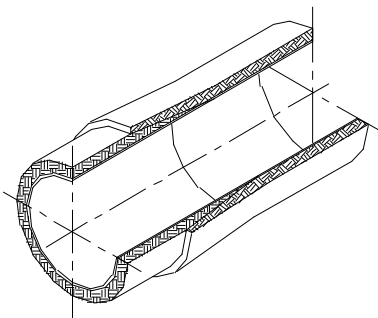

The RPS Tapered Adhesive joint utilizes a matching bell and spigot system combined with a specially formulated adhesive to provide quick and easy assembly of numerous combinations of pipe and fittings.

- ◆ Available in 1"Ø to 12"Ø
- ◆ Quick to assemble (about 3 times faster than butt and wrap joint)
- ◆ Self-aligning due to tapered fit
- ◆ Provides excellent chemical resistance due to continuity of the corrosion barrier and thin adhesive line.
- ◆ Adhesive formulated using the same resin as the pipe (bis-A vinyl ester or epoxy novolac vinyl ester)
- ◆ Some limitations on fittings available (see RPS Dimensional Catalogue for more information)
- ◆ Requires minimal training
- ◆ Requires specialized tool for field tapering (available to rent or purchase).
- ◆ Pipe wall thickness and/or liner thickness may be limited; however various options do exist (consult RPS directly for more information)

BUTT & WRAP JOINT

The Butt and Wrap joint is an industry standard providing simple assembly of an unlimited number of components. RPS offers both a "straight" and "tapered" butt joint with the details summarized below.

Straight Butt & Wrap Joint

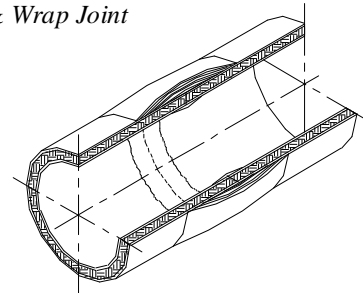

- ◆ Available in all sizes / laminate combinations
- ◆ Simple assembly procedure
- ◆ Provides good corrosion resistance
- ◆ Ends can be "capped" (ex. 2 layers of Veil) to increase corrosion resistance
- ◆ Inside lay-up recommended on larger diameters (> 20") to improve chemical resistance.
- ◆ Provides same axial strength as pipe
- ◆ Has generally lowest burst strength of all bonded joint types
- ◆ Has high bending strength

Tapered Butt & Wrap Joint

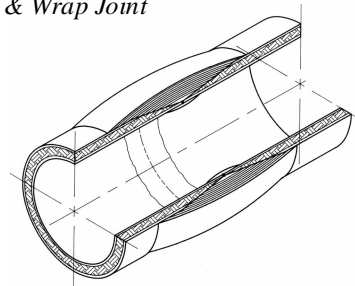

- ◆ Available in all sizes / laminate combinations
- ◆ Offers improved chemical resistance over straight butt joint by providing continuous corrosion liner. Comparable to tapered adhesive joint.
- ◆ Offers increased pressure strength over straight butt joint
- ◆ More time consuming to install than a straight butt joint.
- ◆ More costly than straight butt joint due to increased labour component
- ◆ Requires more sanding in the field compared to straight butt joint.
- ◆ Inside lay-up recommended on larger diameters (> 20") to improve chemical resistance.



FLANGED JOINT

Flanged joints may be used to connect pipe and fittings, and to connect to equipment. RPS offers full face style flanges and Lap Joint style flanges as summarized below. Standard drilling for flanges conforms to ANSI B16.5 Cl.150 for $\leq 24"$ Ø and ANSI B16.47 Series A Cl.150 for $> 24"$ Ø. Other drilling patterns are available (eg. DIN 2501 PN10)

Full Face Flange

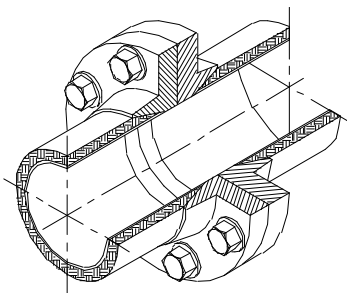

- ◆ Available in all sizes
- ◆ Allow for dismantling of components
- ◆ Quick to assemble in field
- ◆ Most costly of all joint types
- ◆ Experience has shown flanges offer the greatest potential for leaks
- ◆ Requires bolting compatible with the process
- ◆ Requires gaskets compatible with the process although soft (60-70 durometer) EPDM are most common
- ◆ Cannot use “ring” gaskets
- ◆ Can be damaged by over-torquing
- ◆ FRP flanges must be properly aligned to avoid overstressing during installation, cannot be forced into place.
- ◆ Sealing rings on full face flanges provide sealing at lower bolt torques.

Lap Joint Style Flange

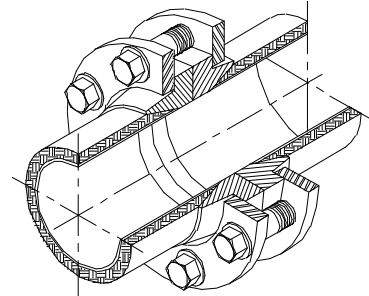

- ◆ Available in all sizes
- ◆ Allows some rotation adjustment
- ◆ Seals at lower torque compared to full face flange
- ◆ Similar cost to full face in large diameters, more costly in small diameters.
- ◆ Also requires proper alignment to prevent overstressing at installation.
- ◆ Loose ring (generally mild steel). Coating should be compatible with the service conditions.
- ◆ Bolts and ring must be compatible to avoid corrosion
- ◆ Sealing rings on lap joint flanges provide sealing at lower bolt torques.

O-RING JOINT

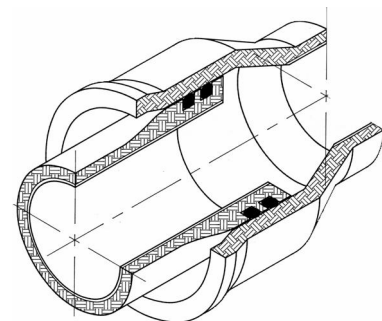

Generally used with large diameter buried pipe to provide quick installation.

- ◆ Available in most sizes
- ◆ Allows for quick installation
- ◆ Available in high pressure ratings
- ◆ Does not provide axial restraint, therefore thrust blocks required at significant changes in direction.
- ◆ Provides approximately 1° of angular adjustment
- ◆ Has good chemical resistance, but for more severe applications, o-ring material must be chosen to suit service conditions.
- ◆ A “double o-ring” allows for testing prior to service
- ◆ Not recommended for slurry applications



GENERAL COMMENTS ON JOINING SYSTEMS

Whenever possible, RPS recommends the use of our *Tapered Adhesive* joining system to provide high chemical resistance and a low installed cost. For sizes 14"Ø and larger, choose the *Straight Butt & Wrap* system, if possible, to minimize sanding in the field and improve installation time. For severe corrosion environments (≥ 14 "Ø), choose the *Tapered Butt & Wrap* system, or choose edge-capping and the straight butt and wrap system. Avoid flanged joints to minimize cost and reduce the risk of leaks. Where flanged joints are necessary, consider Lap Joint flanges on larger diameters (≥ 14 "") to offer adjustment and provide superior sealing capability.

QUALITY ASSURANCE and RESEARCH & DEVELOPMENT

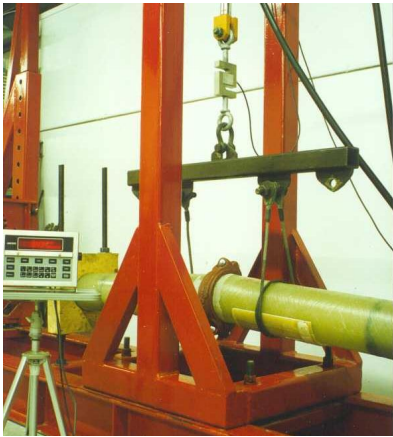

Reinforced Plastic Systems Inc. is certified to ISO 9001 through SGS, one of the world's largest quality assurance certification companies. Our quality assurance program includes written procedures and work instructions covering all

aspects of the Company's operation, including design and document & data control. All calculations and drawings affecting the fit, form or function of our products are reviewed by our engineers to ensure compliance to the required specifications and standards. In addition, our R&D department is continuously testing our existing product line as well as exploring new possibilities to improve existing products or create new products.

REFERENCES



The following is a list of references that contain useful information relating to the design of FRP piping and fittings. The references are categorized by various subjects; however, some of the references may contain information beyond the main subject.

General Information on FRP Design

"Fiberglass Pipe Handbook" – The Composites Institute of the Society of Plastics Industry

"Corrosion Resistant Plastic Composites in Chemical Plant Design" – John H. Mallinson

"Custom Contact Molded Reinforced Polyester Chemical Resistant Process Equipment PS 15-69" – National Bureau of Standards

"Structural Plastics Design Manual" – American Society of Civil Engineers

"Fiberglass Pipe Design – AWWA M45" - American Water Works Association

"Reinforced plastic pipes, fittings and joints for process plants – BS 6464" – British Standards Institute

"Design and construction of glass reinforced plastics (GRP) piping systems for individual plants or sites – BS 7159" – British Standards Institute

Seismic & Wind Design

"Minimum Design Loads for Buildings and Other Structures (ASCE 7)" – American Society of Civil Engineers

Stress Intensification Factors (SIF's)

"Design and construction of glass reinforced plastics (GRP) piping systems for individual plants or sites – BS 7159" – British Standards Institute



Regulatory Codes Applicable to FRP Piping

“Process Piping – ASME B31.3” – American Society of Mechanical Engineers

“Power Piping – ASME B31.1” – American Society of Mechanical Engineers

Pipe Support and Pipe Stress Analysis

“Piping and Pipe Support Systems” – Paul R. Smith / Thomas J. Van Laan

Testing and Research

“Standard Test Method for Tensile Properties of Plastics – ASTM D 638” – ASTM Standard

“Standard Test Method for Flexural Properties – ASTM D 790” – ASTM Standard

“Standard Test Method for Short-Time Hydraulic Failure Pressure of Plastic Pipe, Tubing and Fittings – ASTM D 1599” – ASTM Standard

“Standard Test Method for Longitudinal Tensile Properties of Fiberglass Pipe and Tube – ASTM D 2105” – ASTM Standard

“Standard Method for Indentation Hardness of Rigid Plastics by Means of a Barcol Impressor – ASTM D 2583” – ASTM Standard

“Standard Practice for Obtaining Hydrostatic or Pressure Design Basis for Fiberglass Pipe and Fittings – ASTM D 2992” – ASTM Standard

“Standard Specification for Filament Wound Fiberglass Pipe – ASTM D 2996” – ASTM Standard

“Standard Specification for Machine Made Fiberglass Flanges – ASTM D 4024” – ASTM Standard

“Standard Specification for Contact Molded Fiberglass Flanges – ASTM D 5421” – ASTM Standard